

Material Specifications Example (Double Page Spread)

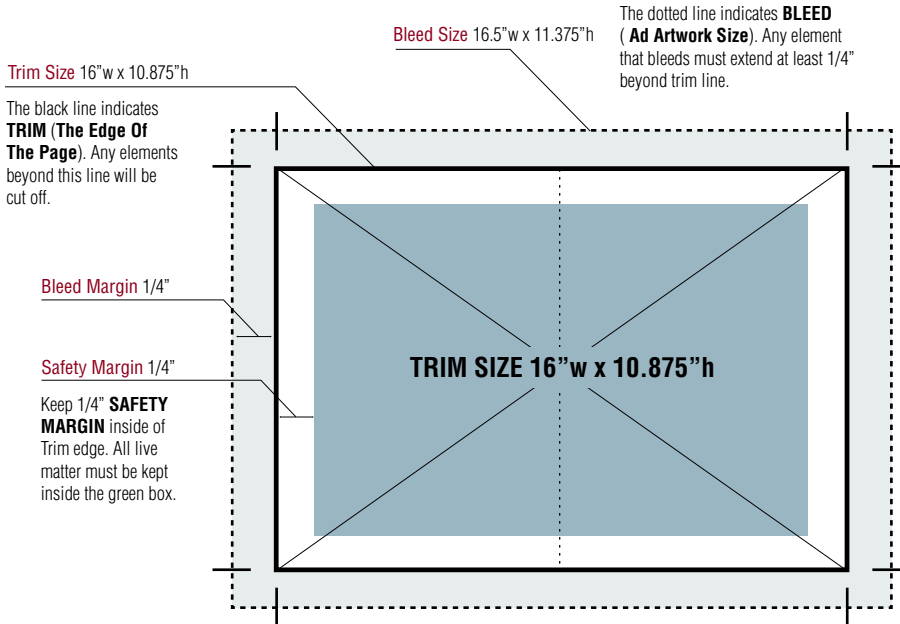

Preferred Material: Digital Files, Film not accepted.

FILE TYPES

Adobe InDesign, Adobe Illustrator, Adobe Photoshop, PDF, TIF, EPS.

Illustrator Files:

- Save Illustrator Images/Documents as **Illustrator EPS** files.
- Convert all fonts to outlines
- Embed all images

PDF Files:

- We strongly recommend supplying **PDF/X-1a** files.
- Files should be CMYK at highest resolution.

IMAGE PREPARATION

- Save all images as either EPS, TIF or PDF files
- Avoid using Jpegs, Gifs, or any other low-resolution modes to save images in
- Save with 8bit MAC preview with Binary encoding

PLATFORM

PC, MAC

MEDIA TRANSPORT

CD ROM/DVD ROM, ZIP (100M), FTP server (Label your file with your company name, and place in the folder of the current issue).

SHIPPING INSTRUCTIONS

Send all ad materials, copy corrections, artwork or any other material pertaining to advertisements to:
Traffic Coordinator, VerticalScope Inc.,
111 Peter St., Suite 700, Toronto, Ontario, Canada, M5V 2H1.

PROOFING: SWOP (Standard Web Offset Press) certified color proofs. We will not be responsible for color or any other deviation from original files without a SWOP color proof. Proofs should accompany the file and should not be folded. Contents of the package should be identified on the outside as to the magazine name, issue and advertiser.

PRODUCTION CHARGES: Design and production assistance is subject to an hourly charge plus additional stripping, proofing and film charges. Other production charges include resizing the ad to meet our required specifications, strip-ins or deletions requested, any altering of file in order to make ad meet bleed size requirements or printing specifications. Publisher is not liable for reproduction quality on mechanicals which require camera work.

SPECIAL INSTRUCTIONS

Resolution **250 dpi minimum**. No fonts or layers accepted. Convert to outlines and flatten artwork. Check that ad is sized to correct specifications. Select all colors (PMS) to CMYK process. * *Note, all ads excluding islands require 1/4" bleeds around the perimeter of the ad.*

Full Page
with Bleed
8.5" w x 11.375" h
Trim Size
8" w x 10.875" h

1/2 Page Horizontal
with Bleed
8.5" w x 5.938" h
Trim Size
8" w x 5.438" h

Double Page Spread
with Bleed
16.5" w x 11.375" h
Trim Size
16" w x 10.875" h

1/2 Double Page Spread
with Bleed
16.5" w x 5.938" h
Trim Size
16" w x 5.438" h

1/3 Page Vertical
with Bleed
3.2" x 11.375" h
Trim Size
2.7" w x 10.875" h
Island
2.2" w x 9.668" h

2/3 page Vertical
with Bleed
5.6" x 11.375" h
Trim Size
5.1" w x 10.875" h

1/3 Page Square
with Bleed
5.6" x 5.938" h
Trim Size
5.1" w x 5.438" h
Island
4.6" w x 4.898" h

1/2 page Island
4.6" x 6.71" h